

“Designer Elite” Screw on Cap Style Roller Ball / Fountain Pen Kits

Kit Features:

- Heavy 24 kt. gold plating with epoxy coating
- Designed to match other PSI Mont Blanc® style pens
- Elite designed center band
- Roller Ball refill with black ink
- Fountain Pen Iridium nib made in Germany
- Overall length: 5-3/4" (closed)

Required Accessories:

- 7mm, long mandrel
- 3 pc bushing set #PKMONT-BU3
- Step drill bit set (2 bits) #PKMONT-SD3
- 2 part epoxy glue or inst-cure (cyanoacrylate glue)

Note: Drawings not to scale

Diagram A / Parts Layout

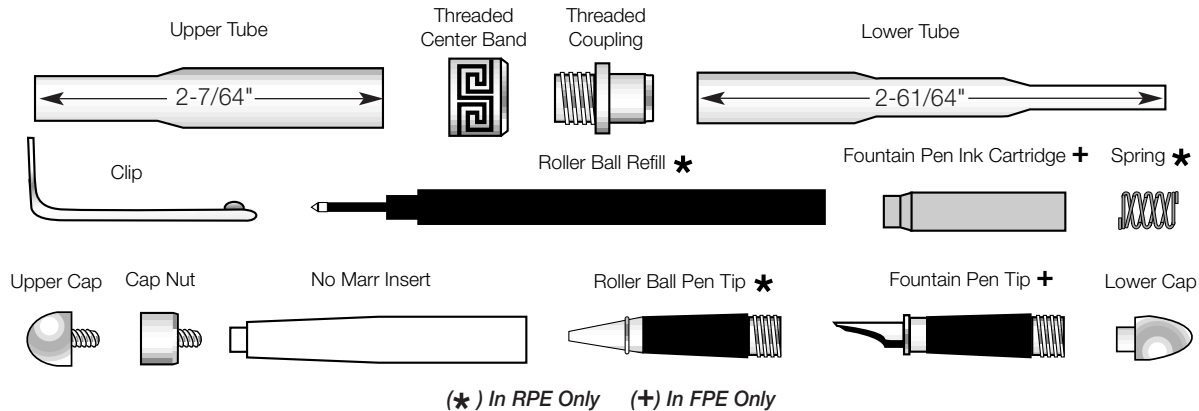

Preparing the Blanks

- Cut 3/4" to 5/8" square blanks to the length of the brass tubes (add 1/16" for squaring off).
- Drill center hole lengthwise through each blank. For the upper blank use the 2 step drill bit. For the lower blank use the 3 step drill bit.
- Spread glue over tubes. Insert into proper blanks with

a twisting motion to spread the glue evenly inside. Center each tube lengthwise in the blanks.

- When the glue dries, square the ends of the blanks. You may use a belt/disc sander to take the wood down flush to the brass tube at each end making sure the ends are perpendicular to the tubes.

Diagram B / Turning the Wood Blanks

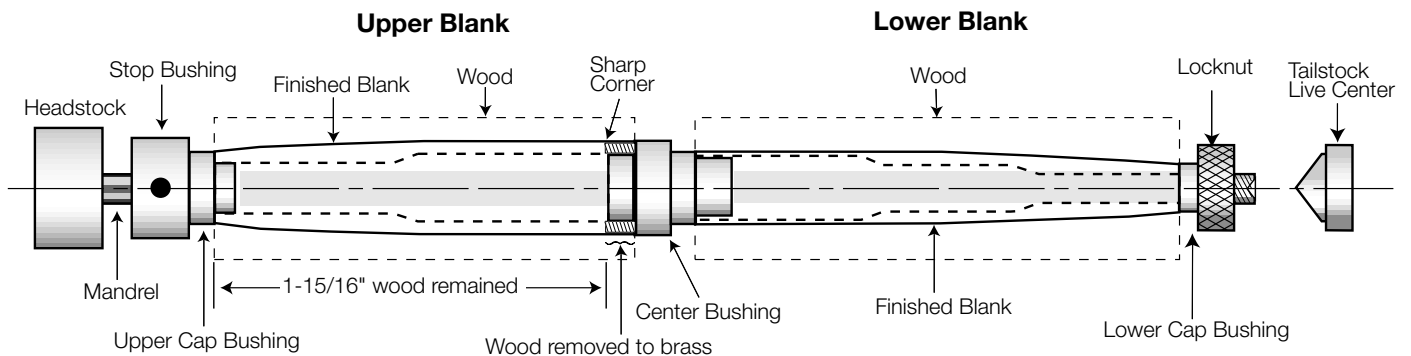

Turning the Blanks

- Place the stop bushing in the mandrel.
- Place the upper cap bushing onto the mandrel, then slide on the upper blank. Next, insert center bushing with the larger diameter first, into upper blank. Slide the lower blank onto mandrel up over the center bushing. Insert the lower cap bushing and thread the lock nut hand tight. Bring up the tailstock snug with the live center (do not over tighten live center, it could damage the mandrel). Tighten both the stop bushing and the lock nut.
- Turn wood down, flush with the bushings using a lathe chisel and sand paper. Taper the ends of the blanks

(follow diagram 'B' for profile) to conform with upper and lower brass end cap bushings.

Note: The wood at the lower cap needs to fit inside the No Marr insert in the Barrel (cap). Be sure to turn the blank narrow at the end section. Check the fit inside the insert before proceeding with sanding.

- **Removing wood for center band:** Place a mark 1-15/16" from the end of the upper blank. Use a parting tool to remove the excess wood down to the brass tube. Continue until brass is completely shined. Be careful, you must retain a sharp 90° corner at the end of the upper blank when you remove the excess wood. Sand both blanks then varnish and/or wax the wood.

Diagram C / Assembly

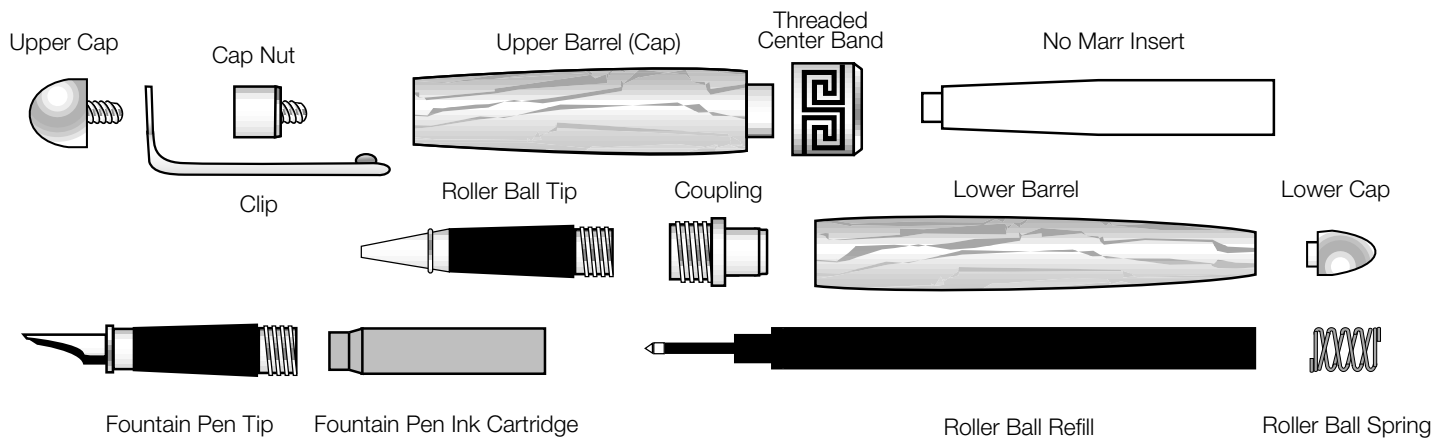

- Notes:**
- These instructions can be used for both the Roller Ball Pen and Fountain Pen. Follow assembly procedures below to properly handle either style.
 - The insert is not the retainer used in PKMONT-RP2. It is used to avoid marring the wood, not to secure the pen closure.
 - The cap should always be screwed on when the pen is not in use to avoid the ink drying up.

Assembly Tips

- Line up the finished parts according to diagram C.
- To press the parts together use a vice or a clamping instrument with wooden jaws. Press slowly with caution keeping all parts aligned to avoid cracking the wood or scratching the gold plated parts.

Upper Blank

- Press the cap nut (screw end first) flush into the tapered end of the blank.
- Place the threaded center band (square end first) over the exposed brass and press. (Band must be flush with the wood with no gaps).
- Insert the upper cap thread into the clip – screw together into the cap nut.
- Slide the no marr insert inside the upper blank (cap) narrow end first. Use a 1/4" Philips head or a sharp end screwdriver to drive the insert to the end.

Lower Blank

- Press the end cap into the tapered end of the lower blank.
- Press the coupling into the opposite end of the lower blank.

For Roller Ball:

- Drop the spring into the blank and insert the refill into the blank up against the spring. Remove the refill tip protective cover.
- Place the tip assembly over the point of the refill and screw it in snugly against the coupling.

OR

For Fountain Pen:

- Place the Fountain Pen ink cartridge into the fountain pen tip with enough pressure to pierce the ink cartridge.
- Screw the tip into the coupling with the cartridge attached.
- Place upper barrel (cap) over the tip or nib. There are four starting thread positions. The thread will lock at each quarter of a turn.

Bushings (#PKMONT-BU3)

